



basic education

Department:
Basic Education
REPUBLIC OF SOUTH AFRICA

**NATIONAL
SENIOR CERTIFICATE**

GRADE 12

MECHANICAL TECHNOLOGY

FEBRUARY/MARCH 2016

MARKS: 200

TIME: 3 hours

This question paper consists of 13 pages and a 4-page formula sheet.

INSTRUCTIONS AND INFORMATION

1. This question paper consists of TEN questions.
2. Read ALL the questions carefully.
3. Answer ALL the questions.
4. Number the answers correctly according to the numbering system used in this question paper.
5. Start EACH question on a NEW page.
6. Show ALL calculations and units. Round off final answers to TWO decimal places.
7. Candidates may use non-programmable scientific calculators and drawing instruments.
8. The value of gravitational force should be taken as 10 m/s^2 .
9. All dimensions are in millimetres, unless stated otherwise in the question.
10. A formula sheet is attached to the question paper.
11. Write neatly and legibly.
12. Use the criteria below to assist you to manage your time.

QUESTION	CONTENT	MARKS	TIME (minutes)
1	Multiple-choice questions	20	15
2	Safety	10	10
3	Tools and Equipment	12	10
4	Materials	13	10
5	Terminology	30	20
6	Joining Methods	25	25
7	Forces	30	30
8	Maintenance	15	15
9	Systems and Control	25	25
10	Turbines	20	20
TOTAL		200	180

QUESTION 1: MULTIPLE-CHOICE QUESTIONS

Various options are provided as possible answers to the following questions. Choose the answer and write only the letter (A–D) next to the question number (1.1–1.20) in the ANSWER BOOK, for example 1.21 D.

- 1.1 Which ONE of the following safety procedures is applicable to the maintenance/operation of a hydraulic press?
- A Do not apply a wrench to revolving work.
 - B Guards could be removed when pressing soft material.
 - C Pressure gauges must be tested regularly and adjusted or replaced if any malfunction occurs.
 - D Use the machine table as an anvil. (1)
- 1.2 Which ONE of the following safety procedures is applicable to the multi-meter?
- A Use water to remove dust around the spark-plug area.
 - B Use only charged cells of the correct size.
 - C Do not exceed the prescribed pressure in the cylinder.
 - D The meter must be tightened well until no hissing sounds can be heard. (1)
- 1.3 Petrus uses the Brinell hardness tester to determine the hardness of a test piece. FIGURE 1.1 shows the test piece during the test. Identify part X.

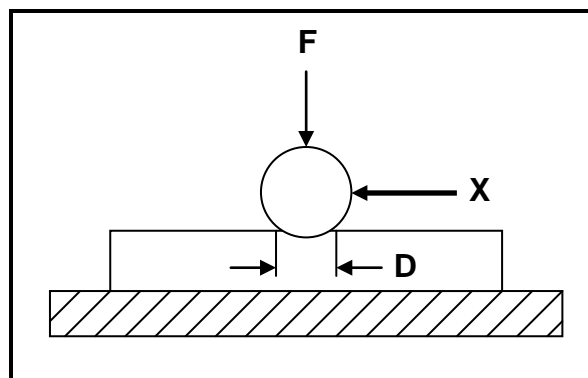

FIGURE 1.1

- A Bearing
 - B Diameter of impression
 - C Test piece
 - D Hardened steel ball (1)
- 1.4 What is the function of a depth micrometer?
- A Tests the properties of compression springs
 - B Determines whether the engine leaks gases from the cylinders
 - C Measures the pitch diameter of a screw thread
 - D Measures the depth of a hole in a work piece accurately (1)

- 1.5 Which structure of steel is characterised as soft and ductile?
- A Ferrite
 - B Pearlite
 - C Cementite
 - D Austenite
- (1)
- 1.6 Which ONE of the following mechanical properties of steel represents resistance to wear?
- A Tempering
 - B Toughness
 - C Hardness
 - D Annealing
- (1)
- 1.7 Determine the width of a parallel key if the diameter of the shaft is 20 mm:
- A 8 mm
 - B 10 mm
 - C 9 mm
 - D 5 mm
- (1)
- 1.8 Which milling method is shown in FIGURE 1.2?

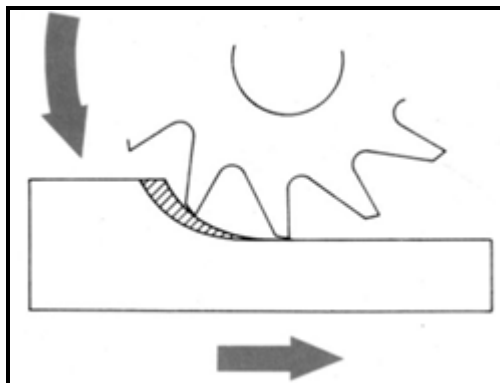

FIGURE 1.2

- A Straddle milling
 - B Gang milling
 - C Up-cut milling
 - D Down-cut milling
- (1)
- 1.9 Which ONE of the following is an advantage of the MIG/MAGS welding process?
- A It uses a lower current.
 - B It can weld in any direction.
 - C Maximum post-weld cleaning is required.
 - D It uses minimum oxygen.
- (1)

- 1.10 Which ONE of the following is the cause of a porous weld?
- A Rapid chilling
 - B Current too high
 - C Slag not removed from the previous run weld
 - D Dirty or wet weld electrode
- (1)
- 1.11 Which term best describes an external force acting upon a material?
- A Strain
 - B Stress
 - C Young's modulus of elasticity
 - D Load
- (1)
- 1.12 The graph in FIGURE 1.3, which compares the stress and the strain, is obtained when a mild steel specimen is subjected to a tensile test. What is represented by point E on the graph?

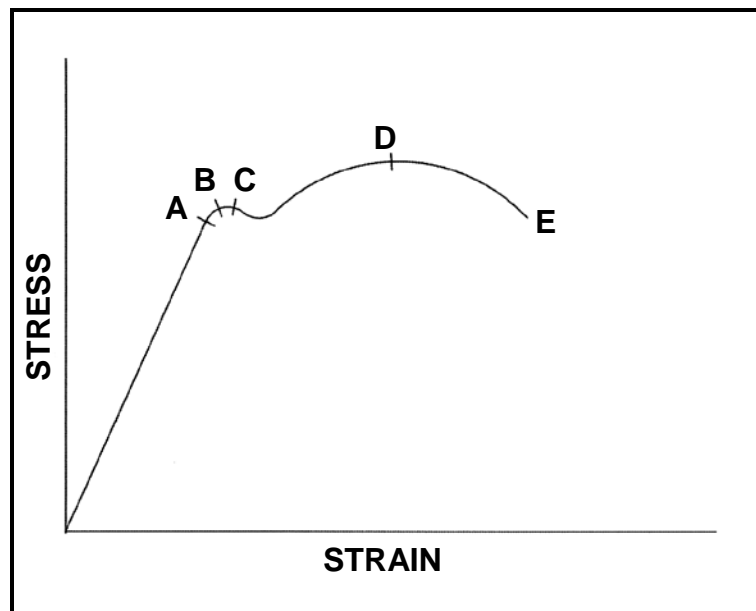

FIGURE 1.3

- A Limit of proportionality
 - B Limit of elasticity
 - C Break stress
 - D Maximum stress
- (1)
- 1.13 What is understood by the term *Young's modulus of elasticity*?
- A The force value required to produce a unit area in a tensile test specimen
 - B The ratio between stress and strain in a metal, provided that the limit of elasticity is not exceeded
 - C A measurement of the extension or contraction of material due to the load experienced
 - D A ratio of the deformation because of the application of an external force
- (1)

- 1.14 What is the function of the clutch in a motor vehicle's drive?
- A To engage and disengage the power from the gearbox to the wheels
 - B To engage and disengage the power from the engine to the gearbox
 - C To engage and disengage the power from the differential to the gearbox
 - D To engage and disengage the power from the engine to the differential (1)
- 1.15 The definition of the viscosity of oil relates to the measure of the oil's ...
- A resistance to flow.
 - B rapid movement to flow.
 - C swift flow movement.
 - D quick movement to flow. (1)
- 1.16 Which ONE of the following statements defines pneumatics?
- A The transfer and control of a force with the help of compressed liquid
 - B The transfer and control of a force with the help of cams
 - C The transfer and control of a force with the help of compressed air
 - D The transfer and control of a force with the help of chains (1)
- 1.17 What will the velocity ratio of a gear system be if the driven gear has 25 teeth and the driver gear 100?
- A 1 : 4
 - B 4 : 1
 - C 1 : 25
 - D 25 : 1 (1)
- 1.18 Determine the belt speed of a belt-drive system with a driver pulley (100 mm diameter) rotating at 10 revolutions per second:
- A 3,14 m.s⁻²
 - B 3,14 m.s¹
 - C 3,14 m.s⁻¹
 - D 3,14 m.s² (1)
- 1.19 What type of nozzle is used in an impulse steam turbine?
- A Extracting nozzle
 - B Rotating nozzle
 - C Moveable nozzle
 - D Fixed nozzle (1)
- 1.20 What type of compressor is used in a turbocharger?
- A Gear type
 - B Centrifugal type
 - C Vane type
 - D Twin screw type (1)

(1)
[20]

QUESTION 2: SAFETY

- 2.1 State TWO safety precautions to be observed after the centre lathe is switched on. (2)
- 2.2 Name TWO safety precautions to be observed when using a tensile tester. (2)
- 2.3 State TWO safety precautions to be observed when using a spring compressor to remove a coil spring from motor vehicle's suspension. (2)
- 2.4 State TWO safety measures to be observed while conducting a cylinder leakage test on an internal combustion engine. Motivate your answer. (4)
- [10]**

QUESTION 3: TOOLS AND EQUIPMENT

- 3.1 Jack conducted a compression test on a four-cylinder petrol engine. He found that the engine has low compression.
- 3.1.1 Name TWO types of compression tests Jack can perform on his car's engine. (2)
- 3.1.2 Give TWO reasons for low compression in the engine. (2)
- 3.2 Name the equipment that is used to check the oil pump for functionality. (1)
- 3.3 Explain, in point form, the procedure when the cooling-system pressure tester is used to test the pressure in the cooling system. (7)
- [12]**

QUESTION 4: MATERIALS

- 4.1 Temperature affects the structure of steel with regard to iron and carbon. State TWO characteristics of each of the following:
- 4.1.1 Pearlite (2)
- 4.1.2 Cementite (2)
- 4.2 Explain the following terms used in the iron-carbon equilibrium diagram:
- 4.2.1 Lower critical point (AC_1) (2)
- 4.2.2 Higher critical point (AC_3) (2)
- 4.3 Which ELEMENT determines the hardness of steel with reference to the iron-carbon equilibrium diagram? (1)
- 4.4 Which STRUCTURE in steel determines the hardness? (1)
- 4.5 Which STRUCTURE in steel determines the ductility? (1)
- 4.6 Describe the austenite structure. (2)
- [13]**

QUESTION 5: TERMINOLOGY

- 5.1 When a broken gear was measured, it was found to have an outside diameter of 112 mm. A replacement gear must be made to mesh with a rack that has a straight-line pitch of 12,567 mm. (Hint: circular pitch = straight-line pitch)

Calculate:

- 5.1.1 The module (round off to a whole number) (3)
- 5.1.2 The pitch-circle diameter (3)
- 5.1.3 The cutting depth (2)
- 5.1.4 The addendum (1)
- 5.1.5 The dedendum (2)
- 5.1.6 The clearance (2)
- 5.1.7 The number of teeth (3)
- 5.2 Calculate the indexing required for the number of teeth of the gear in QUESTION 5.1.7. (4)
- 5.3 Explain, step by step, the procedure to cut an external metric V-screw thread with a pitch of 2 mm on a centre lathe using the compound-slide method. (10)
- [30]**

QUESTION 6: JOINING METHODS

6.1 FIGURE 6.1 shows components of welding equipment. Answer the questions that follow.

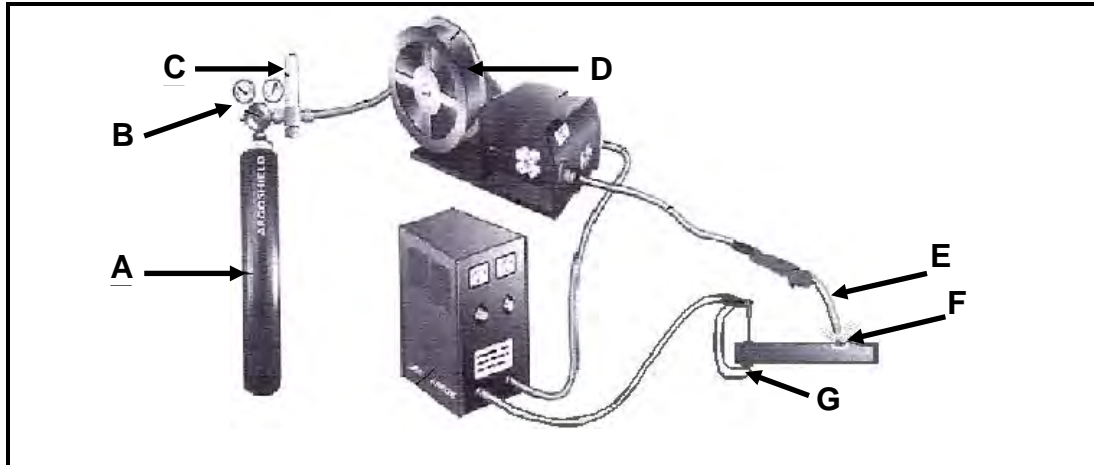

FIGURE 6.1

6.1.1 Identify the type of equipment shown in FIGURE 6.1. (1)

6.1.2 Label components **A–G**. (7)

6.1.3 What is the purpose of the gas during the welding process? (2)

6.2 Name TWO causes of each of the following welding defects:

6.2.1 Slag inclusion (2)

6.2.2 Undercutting (2)

6.3 State TWO measures to prevent the following weld defects:

6.3.1 Lack of fusion (2)

6.3.2 Welding craters (2)

6.4 Explain how you will conduct a dye penetration test on a welded joint. (7)

[25]

QUESTION 7: FORCES

7.1 A system of forces is shown in FIGURE 7.1. Determine, by means of calculations, the magnitude and direction of the resultant for the system of forces in FIGURE 7.1.

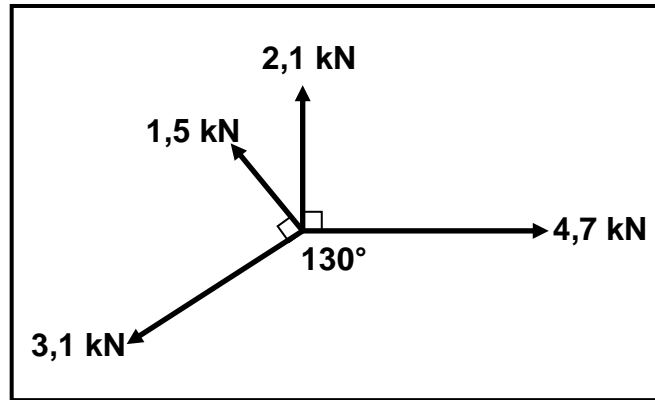

FIGURE 7.1

- 7.1.1 Calculate the resultant of the horizontal components. (4)
- 7.1.2 Calculate the resultant of the vertical components. (4)
- 7.1.3 Calculate the magnitude of the equilibrium force. (4)
- 7.1.4 Calculate the equilibrium angle with reference to the horizontal plane. (3)

7.2 An M16 bolt is used in the link shown in FIGURE 7.2. A load of 600 kg is hanging from the link. Calculate the stress in the bolt material.

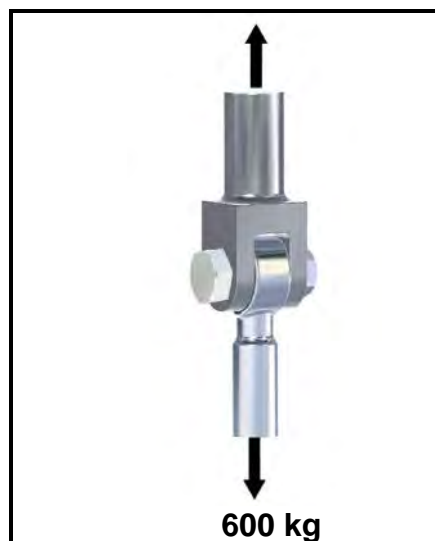

FIGURE 7.2

- 7.3 Define *Pascal* as the unit for stress in a material. (3)

- 7.4 FIGURE 7.3 shows a uniform beam that is supported by two vertical supports, **A** and **B**. Two vertical point loads, 1 400 N and 1 600 N, are exerted onto the beam, as well as a uniformly distributed force of 350 N/m over the total length of the beam. Determine, by means of calculations, the magnitude of the reactions in supports **A** and **B**.

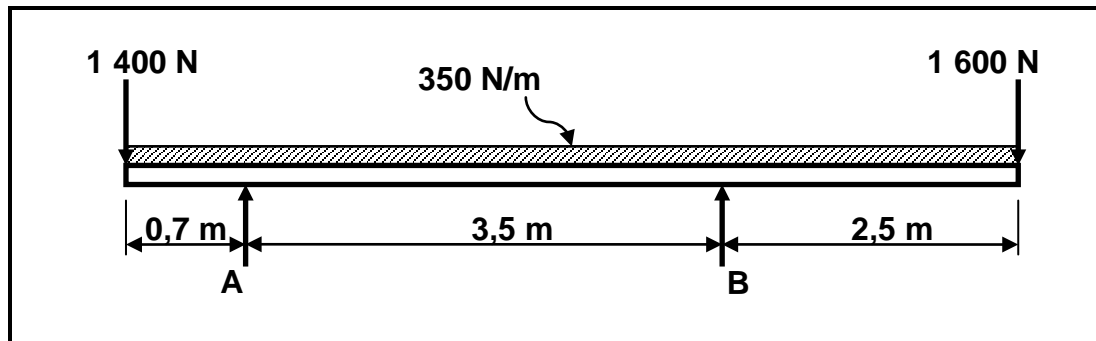

FIGURE 7.3

(6)
[30]**QUESTION 8: MAINTENANCE**

- 8.1 State TWO results of failure to conduct routine maintenance on belt drive systems. (2)
- 8.2 Give TWO reasons why the viscosity of a cutting fluid must be low. (2)
- 8.3 Define the term *flashpoint of a lubricant*. (2)
- 8.4 What does the abbreviation *API* stand for? (2)
- 8.5 State TWO functions of an automatic transmission fluid. (2)
- 8.6 Explain the procedure to replace the belt in a V-belt drive system of a drill press. (5)

[15]

QUESTION 9: SYSTEMS AND CONTROL

- 9.1 A driver gear on the shaft of an electrical motor has 30 teeth and meshes with a gear on a countershaft which has 80 teeth. There is a driver gear with 40 teeth on the countershaft that meshes with the final driven gear, which has 63 teeth and rotates at 2 r.s^{-1} . Draw a diagrammatical representation of the gear system to assist you with the calculations below.

Determine, by means of calculations:

- 9.1.1 The rotation frequency of the electrical motor (5)
- 9.1.2 The speed ratio of the gear train (2)

- 9.2 A pulley with a diameter of 800 mm is mounted on a shaft of a washing machine. The washing machine is driven from a pulley with a diameter of 600 mm which rotates at a speed of $7,2 \text{ r.s}^{-1}$. The tensile force in the tight side of the belt is 300 N. The ratio between the tensile force in the tight side and the tensile force in the slack side is 2,5 : 1. (Belt thickness may be ignored.)

Determine, by means of calculations:

- 9.2.1 The rotational frequency of the pulley on the washing machine (3)
- 9.2.2 The power that can be transmitted (3)
- 9.3 How can the volume of a certain mass of gas be changed? (2)
- 9.4 Define Boyle's law with reference to gases. (3)
- 9.5 A hydraulic system is used to compress scrap metals for recycling. The specifications of the system are shown diagrammatically in FIGURE 9.1.

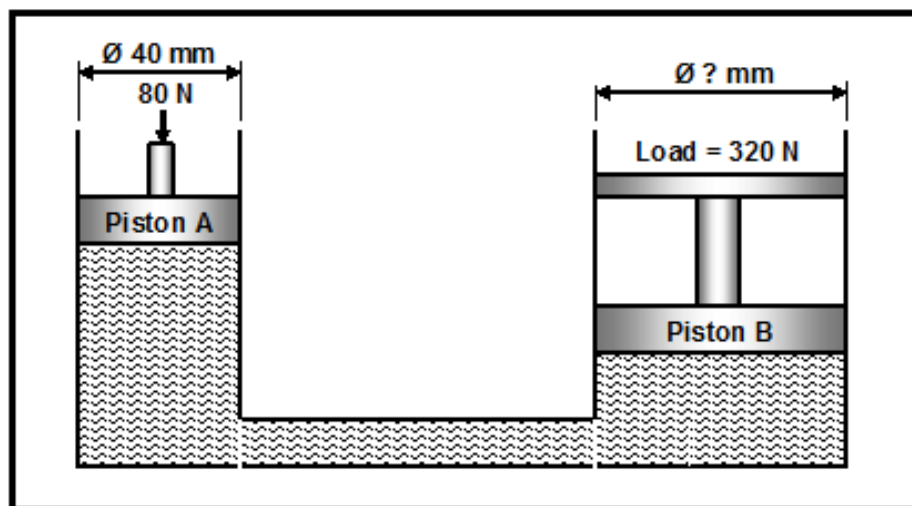

FIGURE 9.1

Determine, by means of calculations:

- 9.5.1 The fluid pressure in the hydraulic system when in equilibrium (3)
- 9.5.2 The diameter of piston B (4)
- [25]**

QUESTION 10: TURBINES

- 10.1 What is the purpose of the blades on the water turbine? (2)
- 10.2 Name TWO types of water turbines that can be used to reverse flow and also operate as a pump to fill a high-lying reservoir during off-peak electrical hours. (2)
- 10.3 Name TWO types of superchargers used on motor vehicle engines to improve performance. (2)
- 10.4 Explain the operation of the turbocharger. (5)
- 10.5 Name TWO advantages of a supercharger in comparison with a turbocharger. (2)
- 10.6 Explain the term *turbo lag*. (3)
- 10.7 State TWO ways in which a supercharger can be driven. (2)
- 10.8 Name TWO disadvantages of gas turbines. (2)

[20]**TOTAL: 200**

FORMULA SHEET**1. BELT DRIVES**

$$1.1 \quad \text{Belt speed} = \frac{\pi DN}{60} \quad \text{where } N \text{ is in r/min}$$

$$1.2 \quad \text{Belt speed} = \frac{\pi (D + t) \times N}{60} \quad (t = \text{belt thickness})$$

$$1.3 \quad \text{Belt mass} = \text{area} \times \text{length} \times \text{density} \quad (A = \text{thickness} \times \text{width})$$

$$1.4 \quad \text{Speed ratio} = \frac{\text{diameter of driven pulley}}{\text{diameter of driver pulley}}$$

$$1.5 \quad N_1 D_1 = N_2 D_2$$

$$1.6 \quad \text{Open-belt length} = \frac{\pi(D + d)}{2} + \frac{(D - d)^2}{4c} + 2c$$

$$1.7 \quad \text{Crossed-belt length} = \frac{\pi(D + d)}{2} + \frac{(D + d)^2}{4c} + 2c$$

$$1.8 \quad \text{Ratio of tight side to slack side} = \frac{T_1}{T_2}$$

$$1.9 \quad \text{Power (P)} = \frac{(T_1 - T_2) \pi D N}{60} \quad \text{where } N \text{ is in r/min}$$

T_1 = force in the tight side

T_2 = force in the slack side

$T_1 - T_2$ = effective force (T_e)

$$1.10 \quad \text{Power (P)} = (T_1 - T_2) \times V \quad \text{where } V = \text{belt speed in m/s}$$

$$1.11 \quad \text{Power (P)} = \frac{2 \pi N T}{60} \quad \text{where } N \text{ is in r/min}$$

$$1.12 \quad \text{Width} = \frac{T_1}{\text{permissible tensile force}}$$

2. STRESS AND STRAIN

$$2.1 \quad \text{Stress} = \frac{\text{force}}{\text{area}} \quad \text{or} \quad (\sigma = \frac{F}{A})$$

$$2.2 \quad \text{Strain } (\varepsilon) = \frac{\text{change in length } (\Delta L)}{\text{original length } (L)}$$

$$2.3 \quad \text{Young's modulus } (E) = \frac{\text{stress}}{\text{strain}} \quad \text{or} \quad (\frac{\sigma}{\varepsilon})$$

$$2.4 \quad \text{Area of a round bar} \quad A = \frac{\pi d^2}{4}$$

$$2.5 \quad \text{Area of a pipe} \quad A = \frac{\pi(D^2 - d^2)}{4}$$

3. HYDRAULICS

$$3.1 \quad \text{Pressure } (P) = \frac{\text{force } (F)}{\text{area } (A)}$$

$$3.2 \quad \text{Volume} = \text{cross-sectional area} \times \text{stroke length}$$

$$3.3 \quad \text{Work done} = \text{force} \times \text{distance}$$

4. KEYS

$$4.1 \quad \text{Width of key} = \frac{\text{diameter of shaft}}{4}$$

$$4.2 \quad \text{Thickness of key} = \frac{\text{diameter of shaft}}{6}$$

$$4.3 \quad \text{Length of key} = 1,5 \times \text{diameter of shaft}$$

$$4.4 \quad \text{Standard taper for taper key: 1 in 100 or 1 : 100}$$

5. LEVERS

$$5.1 \quad \text{Mechanical advantage (MA)} = \frac{\text{load } (W)}{\text{effort } (F)}$$

$$5.2 \quad \text{Velocity ratio} = \frac{\text{input movement}}{\text{output movement}}$$

$$5.3 \quad \text{Input movement (IM)} = \text{effort} \times \text{distance moved by effort}$$

$$5.4 \quad \text{Output movement (OM)} = \text{load} \times \text{distance moved by load}$$

6. GEAR DRIVES

$$6.1 \quad \text{Power (P)} = \frac{2 \pi N T}{60}$$

$$6.2 \quad \text{Gear ratio} = \frac{\text{product of the number of teeth on driven gears}}{\text{product of the number of teeth on driver gears}}$$

$$6.3 \quad \frac{N_{\text{input}}}{N_{\text{output}}} = \frac{\text{product of the number of teeth on driven gears}}{\text{product of the number of teeth on driver gears}}$$

$$6.4 \quad \text{Torque} = \text{force} \times \text{radius}$$

$$6.5 \quad \text{Torque transmitted} = \text{gear ratio} \times \text{input torque}$$

$$6.6 \quad \text{Module (m)} = \frac{\text{pitch-circle diameter (PCD)}}{\text{number of teeth (T)}}$$

$$6.7 \quad N_1 T_1 = N_2 T_2$$

$$6.8 \quad \text{Pitch-circle diameter (PCD)} = \frac{\text{circular pitch (CP)} \times \text{number of teeth (T)}}{\pi}$$

$$6.9 \quad \text{Outside diameter (OD)} = \text{pitch-circle diameter (PCD)} + 2 \text{ module}$$

$$6.10 \quad \text{Addendum} = \text{module (m)}$$

$$6.11 \quad \text{Dedendum} = 1,157 \text{ m} \quad \text{or} \quad \text{Dedendum} = 1,25 \text{ m}$$

$$6.12 \quad \text{Cutting depth} = 2,157 \text{ m} \quad \text{or} \quad \text{Cutting depth} = 2,25 \text{ m}$$

$$6.13 \quad \text{Clearance} = 0,157 \text{ m} \quad \text{or} \quad \text{Clearance} = 0,25 \text{ m}$$

$$6.14 \quad \text{Circular pitch (CP)} = m \times \pi$$

7. SCREW THREADS

$$7.1 \quad \text{Pitch diameter} = \text{outside diameter} - \frac{1}{2} \text{ pitch}$$

$$7.2 \quad \text{Pitch circumference} = \pi \times \text{pitch diameter}$$

$$7.3 \quad \text{Lead} = \text{pitch} \times \text{number of starts}$$

$$7.4 \quad \text{Height of screw thread} = 0,866 \times \text{pitch}$$

$$7.5 \quad \text{Depth of screw thread} = 0,613 \times \text{pitch}$$

8. INDEXING

8.1 Cincinnati dividing head table for milling machine

Hole circles											
Side 1	24	25	28	30	34	37	38	39	41	42	43
Side 2	46	47	49	51	53	54	57	58	59	62	66

8.2 Indexing = $\frac{40}{n}$ (where n = number of divisions)